

MONTAGEANLEITUNG

ASSEMBLING INSTRUCTIONS

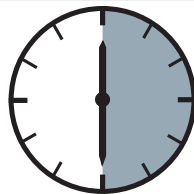

30 Minuten

weight: ca. 0,25 kg



SWITCH HOLDER / SCHALTER HALTER

- Artikel-Nr: 19R 5212

Wild Land Drivers GmbH
Sportplatzstr. 4
D-85635 Höhenkirchen b.München

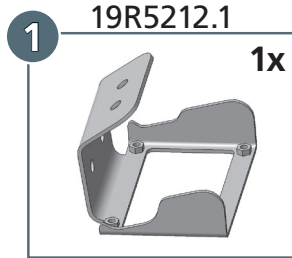
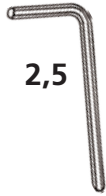
E-Mail: info@wild-land-drivers.de
Phone: +49 (0) 8 10 2 / 89 58-16



	M4x10; ähnl. ISO 7380 Zn	4x
	Ø4; DIN 127 Zn	4x

Bestellnummer
Order number
19R5212X

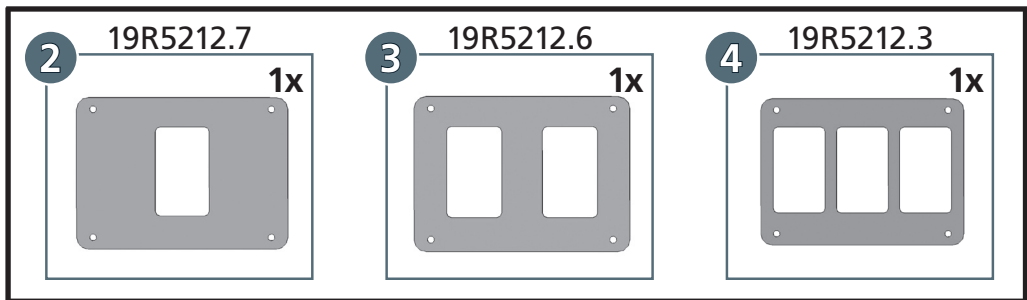

Bestellnummer
Order number
19R5212A

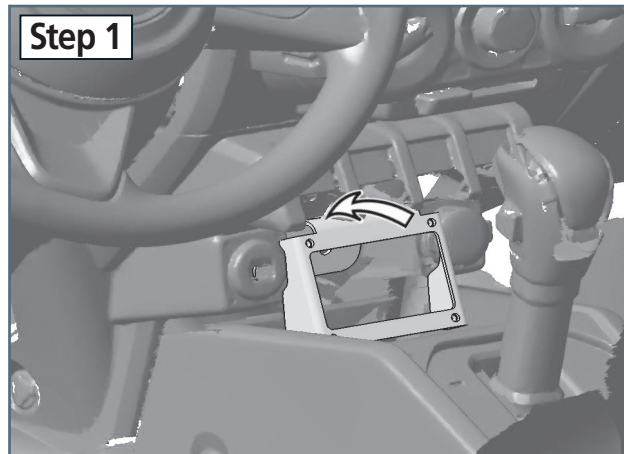
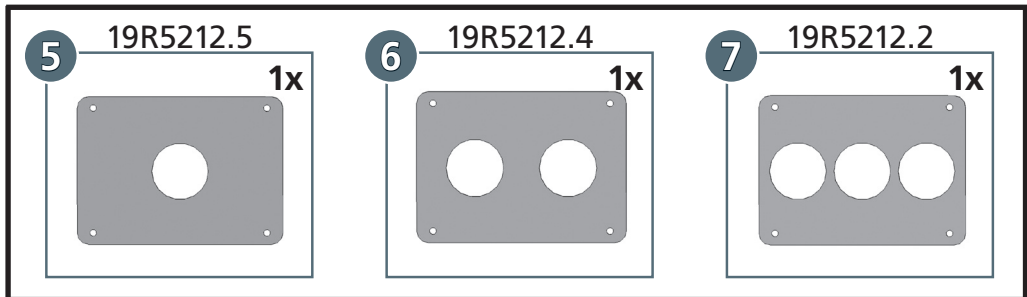

article no.:
19R5212

Revision 2: 07.12.2021



